

2115-137 Block Upconverter, 13.75 - 14.5 GHz

The 2115-137 Block Upconverter converts 0.95 - 1.7 GHz to 13.75 - 14.5 GHz with a local oscillator at 12.8 GHz. Front panel LEDs provide indication of DC Power, External 10 MHz, and PLL Alarm. The L-band to RF gain is +20 dB (+20 to +5 dB continuously variable with Option VA). Connectors are SMA female for the RF and BNC female for the L-Band and external reference input and reference output. A three-way switch controls which 10 MHz reference is being used. In the INT position, the internal reference is used, in the EXT position, the external reference is used, and in the AUTO position, the internal reference is used unless a +3 dBm ± 3 dB, 10MHz reference signal is connected to the external reference input. The 2115 is powered by a 100-240 ± 10% VAC power supply, and mounted in a 1 3/4" X 19" X 14" rack mount chassis.

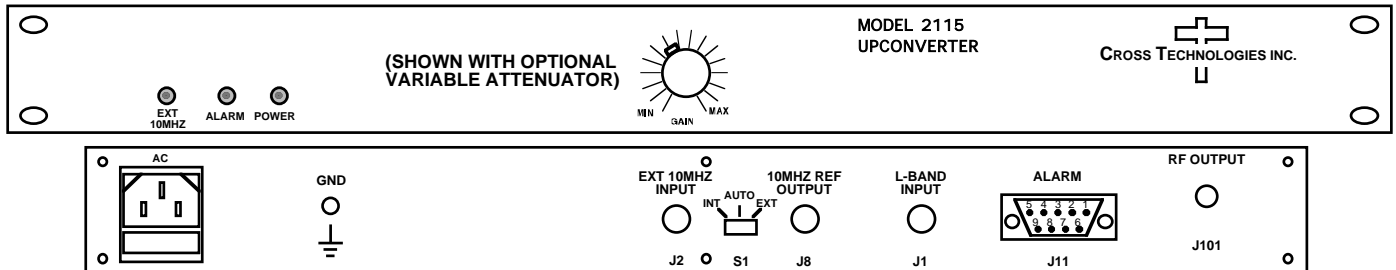

Front and Rear Panels

EQUIPMENT SPECIFICATIONS*

Input Characteristics

Impedance/Return Loss 50Ω/14 dB
 Frequency 0.95 to 1.7 GHz
 Noise Figure, Max. 20 dB max gain
 Level range -40 to -25 dBm
 1 dB compression -15 dBm

Output Characteristics

Impedance/Return Loss 50 Ω /14 dB
 Frequency 13.75 to 14.5 GHz
 Level Range -20 to -5 dBm
 1 dB compression +5 dBm

Channel Characteristics

Gain +20 ±1 dB, (+20 to +5 dB continuously variable with **-VA** Variable Attenuator Option)
 Image Rejection > 60 dB, min
 Spurious, Inband SIGNAL RELATED<-60 dBC in band, -5 dBm out; SIGNAL INDEPENDENT,<-60 dBm
 Spurious, Out of band <-50 dBm
 Intermodulation <-55 dBC for two carriers each at -10 dBm out
 Frequency Response ±1 dB, 13.75 - 14.5 GHz out; ± 0.5 dB, 40 MHz BW
 Frequency Sense Non-inverting

LO Characteristics

LO Frequency 12.8 GHz
 Frequency Accuracy ± 0.01 ppm max over temp internal reference; ext. reference input standard
 10 MHz level +3 dBm, ± 3 dB, 75 ohms, External In or Internal out

Phase Noise @ F (Hz) >	100	1K	10K	100K	1M
dBC/Hz	-70	-80	-85	-100	-110

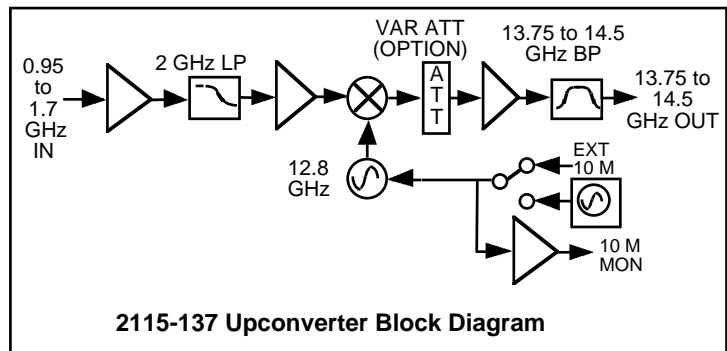

2115-137 Upconverter Block Diagram

Controls, Indicators

Attenuator Option -VA +20 to +5 dB continuously variable gain via front panel control.
 INT/AUTO/EXT Switch Selects internal or external 10 MHz (rear panel DP3T switch)
 Ext 10 MHz Yellow LED, indicates external 10 MHz reference selected
 PLL Alarm Red LED, External contact closure
 Power Green LED

Other

RF Connector SMA (female), 50Ω, standard
 L-Band Connector BNC (female), 50Ω, standard
 10 MHz connectors BNC (female), 75Ω connector; Works with 50Ω or 75Ω
 Alarm Connector DB9 - NO or NC contact closure on Alarm
 Size 19 inch standard chassis 1.75" high X 14.0" deep
 Power 100-240 ±10% VAC, 47 - 63 Hz, 25 watts max.

Available Options

VA, +20 to +5 dB continuously variable gain
Connector/Impedance
 M - 50Ω N-type (RF), 50Ω BNC (L-BAND)
 N - 50Ω N-type (RF), 75Ω BNC (L-BAND)
 NF - 50Ω N-type (RF), 75Ω F-type (L-BAND)
 NN - 50Ω N-type (RF), 50Ω N-type (L-BAND)
 S7 - 50Ω SMA (RF), 75Ω BNC (L-BAND)
 SF- 50Ω SMA (RF), 75Ω F-type (L-BAND)
 SN - 50Ω SMA (RF), 50Ω N-type (L-BAND)
 SS - 50Ω SMA (RF), 50Ω SMA (L-BAND)

*+10 to +40 degrees C; Specifications subject to change without notice